

Installation, Adjustment and Product Care



Section 1: Installation

Tools Provided	2
Installation Overview	3
Installing Window & Patio Door Tilt-Turn Hardware.....	8
Installing Entry Door Hardware & Locksets.....	9

Section 2: Operation and Adjustments

Operation of Tilt-Turn Windows & Patio Doors.....	10
Window & Patio Door Sash Adjustments.....	11
Entry Doors Adjustments	17
Sash Removal	18

Section 3: Product Care & Maintenance

Touch-up Paint & Glazing.....	20
Caring for your Windows, Doors and Screens	21

Section 1

Installation

- Tools Provided**
- Typical Installation**
- Typical Installation Examples**
- Window & Patio Doors Hardware**
- Entry Door Hardware & Locksets**

Tools Provided

Hardware adjustment tools are provided to the customer and/or the General Contractor. Before adjusting any window or door, you should first get a general understanding of the adjustment tools that are provided.



MACO tool:

1. Temporary handle during installation and construction
2. Used to pull out hinge pins to remove sash
3. Spare "Hinge Pin Puller" can be found inside the tool.



Use the tool as a temporary handle to operate the window during installation and construction.



Use the other end of the tool to help pull down hinge pins when removing the sash.

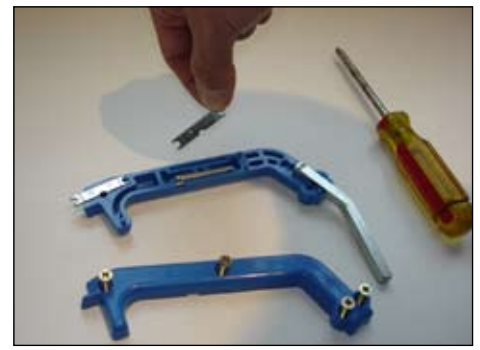

Spare "Hinge Pin Puller" can be found inside the tool. Remove the 4 Phillips head screws to access the spare parts.



U-hex:

This tool is used to adjust various settings of the window and door hardware. Detailed information on adjustment techniques using this tool can be found in the section "Adjusting Window & Patio Door Hardware".

The reason this tool is "U" shaped is to adjust hinges that are in tight areas. This tool can adjust a hinge that is 5/8" from the wall.



Adjusting hinges from the outside.



Adjusting hinges in tight areas, spaces as small as 5/8".



Adjusting hinges from the inside.

Installation Overview

Illustrated below is a cross section of a properly installed window

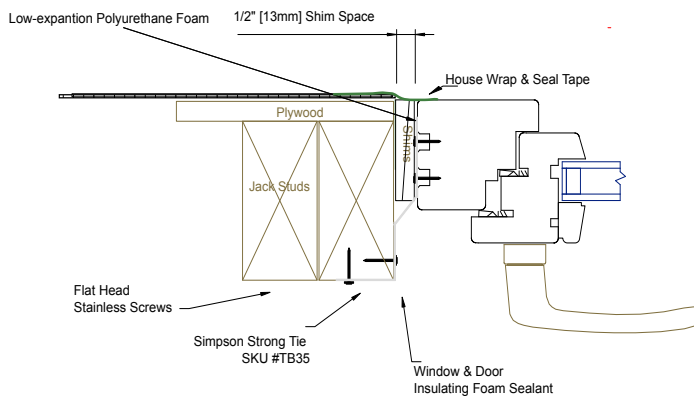

- Simpson Strong Ties are used to secure the window frame to the building framing.
- Stainless steel screws are used to fasten the Simpson Strong Ties to the window frame and building frame.
- Foam Insulating Sealant is applied to the interior seam, silicon is used on the exterior seam.
- Building paper and window/door flashing are properly placed on and around the rough opening.



Typical Window Installation

Use Simpson Strap Tie #TB35, or the strap tie specified by your European Architectural Supply representative. Consult with your EAS representative to determine the number of ties used and spacing.

1. Building paper and window/door flashing should be on and around the RO per manufacturer's specifications.
2. The Simpson Strap is first screwed to the window frame.
3. Next, the window is placed into the RO and is shimmed plumb, level and square.
4. The Simpson Strap Ties are bent into the interior framing and then screwed into place.
5. Once the window is plumb, level, and secure, tape the exterior seam and foam-seal the interior seams and silicon the exterior seams.
6. All units are fully finished: All the wood surfaces you see are the final finish. They should be protected from paints, stucco, drywall dust, and debris created by other trades.



Installation Examples

EFIS & Stucco Systems

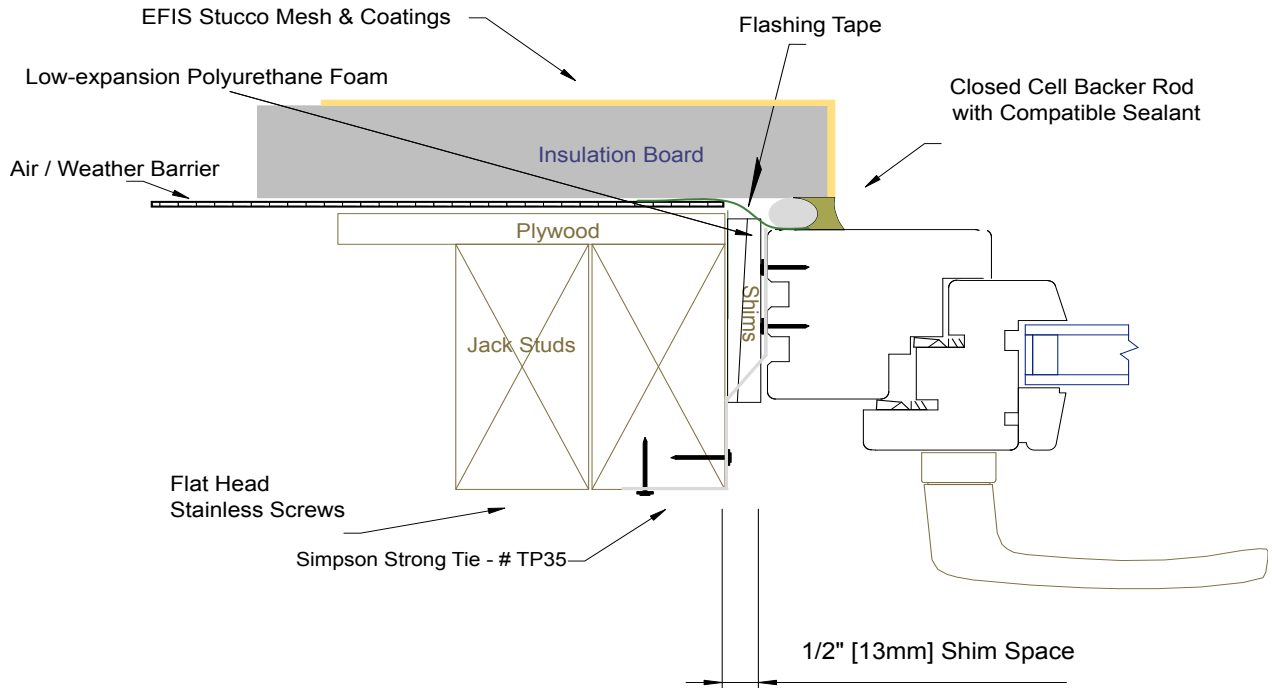

Wood Sidewall

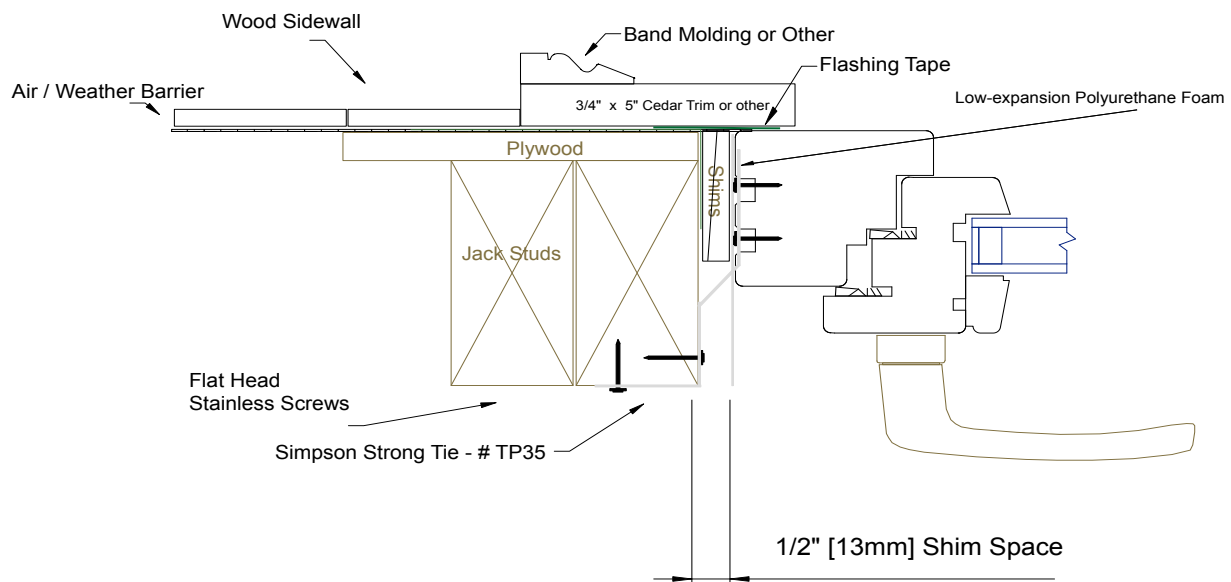

Brick

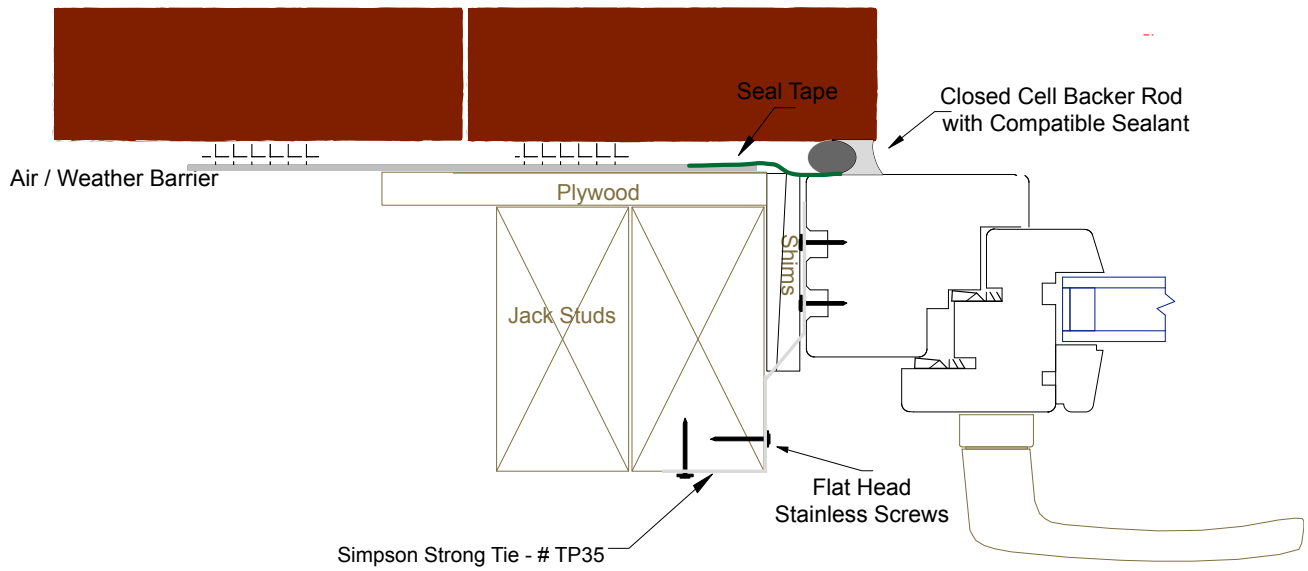

Stone & Veneers

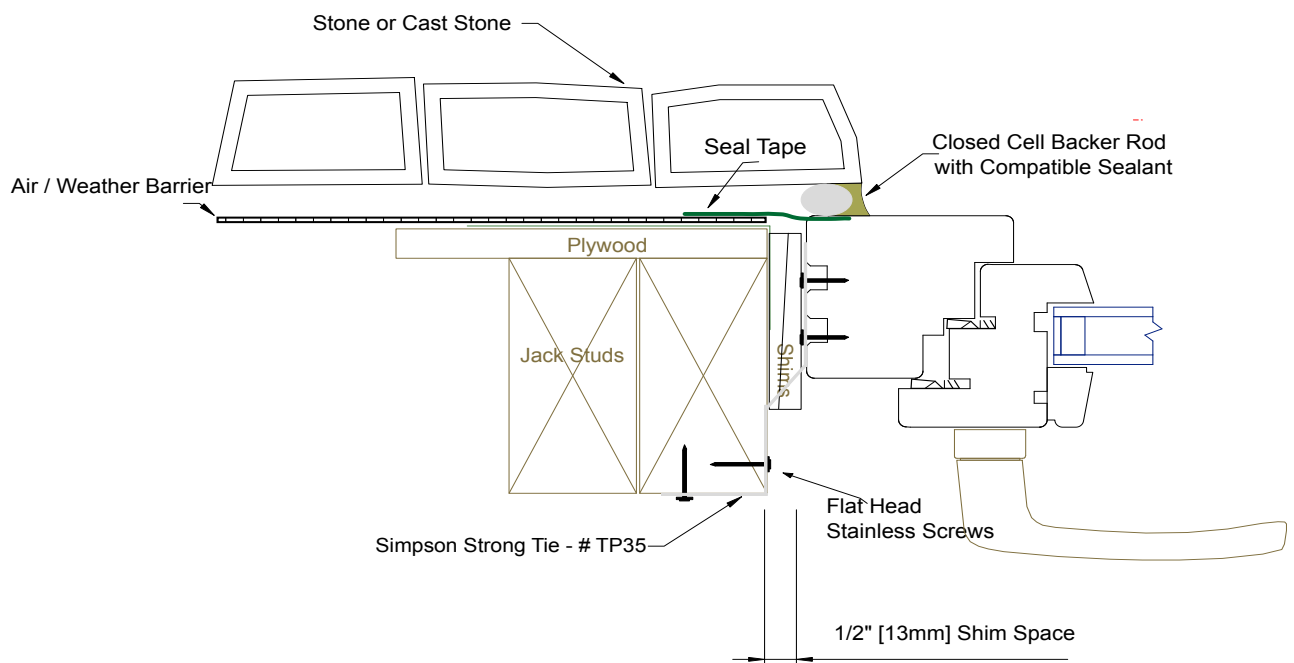

Installing Window & Patio Door Hardware



Tools Needed: Phillips Screwdriver.



(1) With the unit fully closed and locked, loosely set the handle into place.



(2) Turn the handle and swing open the unit.



(3) Once the unit is opened and handle is horizontal, pull and rotate the hardware cover to expose the screws.



(4) Ensure both screws are accurately positioned into the mortised holes, then tighten with a Phillips screwdriver.

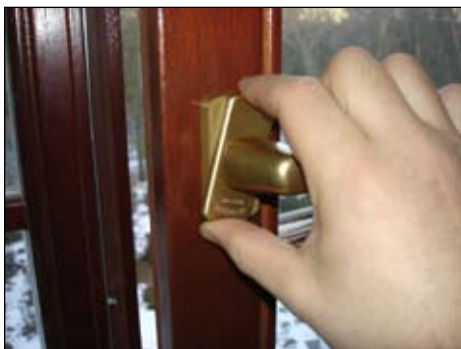

(4) Once the screws are set, rotate the hardware cover to hide the screws.



(5) Close the window sash and turn the handle down into the Closed-Position.



(6) Verify Window & Patio Door Handle is in the correct position when "Closed".

Recommendation:

You should install the window handles as late in the construction process as possible. The MACO tool (found on page 2) can be used to open the window instead of the finish hardware. Reasons why this is recommended:

- Protects the finish hardware during construction
- To prevent stress that might be put on the hardware if other trades working do not know how to operate European style hardware
- Ensure all windows and doors are closed when unattended
- Reduces construction debris between weather stripping and gaskets

Installing Entry Door Hardware

Please note:

Below is an installation example of the hardware. Mortise holes and installation might vary if you have selected different hardware.

Tools Needed:

- Phillips & Flathead screwdrivers
- Allen wrench

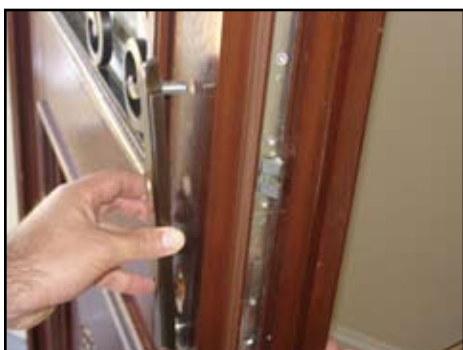
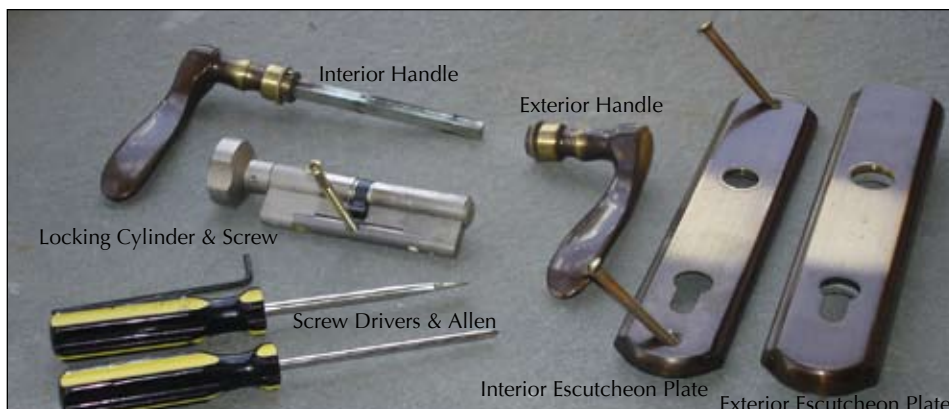

Slide exterior escutcheon plate into pre-mortised holes.

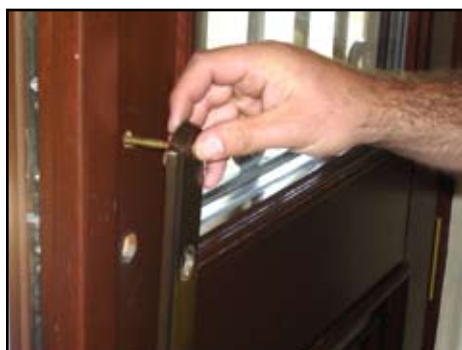

Slide the two screws into the interior escutcheon plate. Slide the screws into the pre-mortised holes until the screws make contact with the exterior plate. Gently screw by hand, then loosely tighten with screw driver .



Rotate locking strike until it is flush with the cylinder. The strike needs to be flush so you can slide it into the pre-mortised hole and interior hardware. With the door opened, slide the key cylinder into the pre-mortised hole.

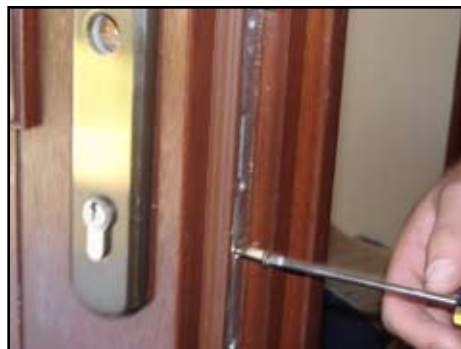

Slide screw in hole adjacent to the cylinder. Gently screw by hand, then tighten with screw driver.

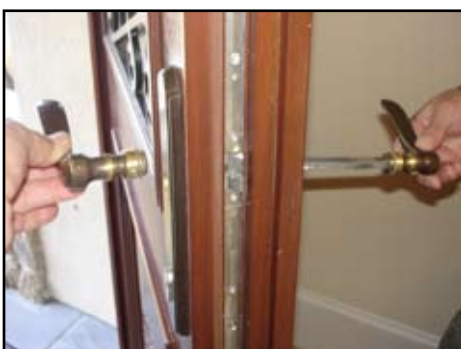

Slide the interior handle stem through the pre-mortised holes into the exterior handle. Once the two handles are firmly connected, gently tighten the nut located on the exterior with an Allen wrench.

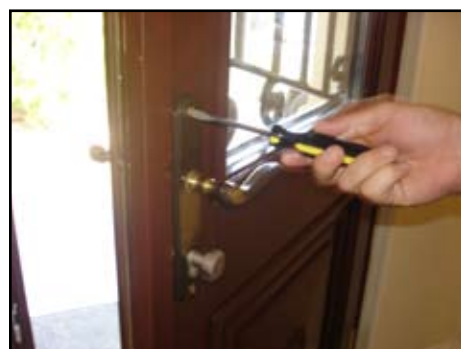
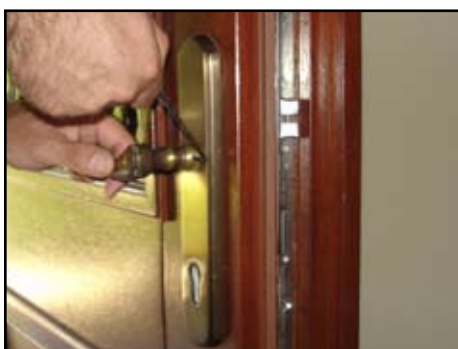

Tighten all screws: Escutcheon plate, locking cylinder and hex screw on exterior handle

Section 2

Operation & Adjustments

- **Operation of Windows & Patio Doors**
- **Window & Patio Door Sash Adjustments**
- **Entry Doors Adjustments**
- **Sash Removal**

Operating a Tilt & Turn Window and Patio Door

Swing Open:

Swing open only for a short and deep air exchange or to clean the exterior glass. Never leave a door open or unattended when children or pets are present. Do not leave the window in this position without sash control or holdbacks.



Rotated the handle horizontally, then swing open the sash.

Tilt Open:

Tilt position is for room ventilation. Please note: Before Tilting or Micro-venting, the unit should be in the closed position. Closing the sash first will ensure proper hardware engagement.



Rotate the handle up 180 degrees, then gently pull to tilt-open the sash. Always push close the sash before attempting to change the handle position.

Micro-venting:

Micro-venting is for minimal room ventilation. Please note: Before Tilting or Micro-venting, the unit should be in the closed position. Closing the unit first will ensure proper hardware engagement.



Rotate the handle approximately 135 degrees, then gently pull to micro-tilt open the sash. Always push close the sash before attempting to change the handle position.

Window & Patio Door Sash Adjustments

Over time the effects of settlement and everyday use might require your windows or doors to be adjusted. European Architectural Supply hardware system enables the window or door sash to be adjusted in many different ways.

Steps to Successfully Adjust a Window

1. Tools that you will need to get the job done
2. Identify & accessing the Adjustment points
3. Identify the Problem
4. Make the adjustments

STEP 1: Tools Required:

U-HEXtool provided

Flat head screw driver



STEP 2: Identify the Adjustment Points

There are three different points where your window sash can be adjusted. Use the U-Hex tool provided by EAS for these 3 Adjustments.

A: Sash Height

Moves the entire sash UP or DOWN

B: Upper Hinge Offset

This adjustment moves the top of the sash towards the upper hinge or away from it.

C: Lower Hinge Offset

This adjustment moves the bottom of the sash towards the lower hinge or away from it.

PLEASE NOTE:

Adjust Slowly. With every adjustment, turn the Allen screw 1/4 turn, then operate the window or door to see if you have corrected the problem. Repeat if necessary: turn the screw approximately 1/4 turn each time, until the issue is resolved. As you correct the problem with one adjustment, you may cause the sash to bind or hit in another place. This means you may have to make more than one adjustment to correct all of the binding problems.

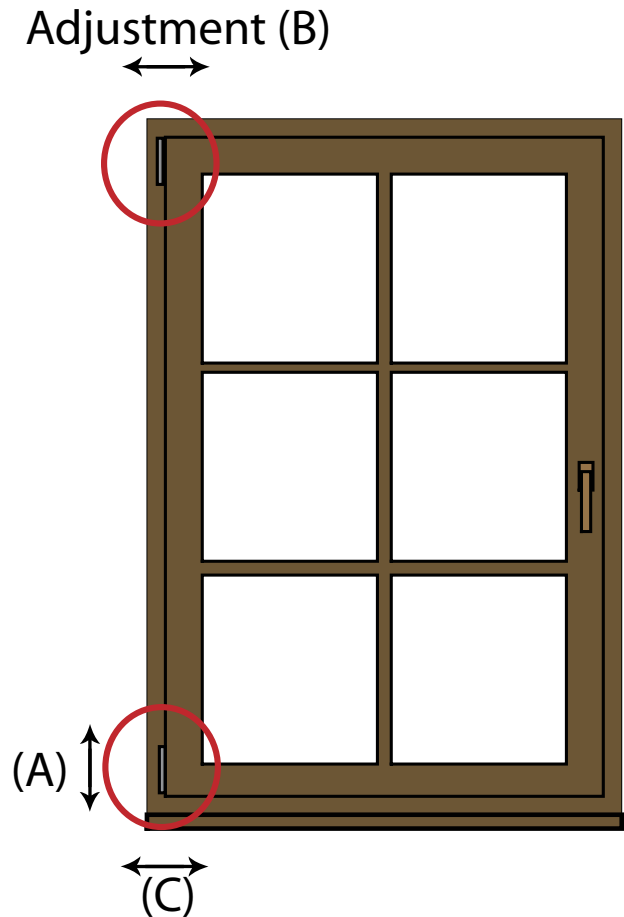

Accessing the Adjustment Points

To access the Adjustment point C you will need to remove the Top Hinge Cover.



Remove top Hinge Cover

STEP 3: Identify the Problem

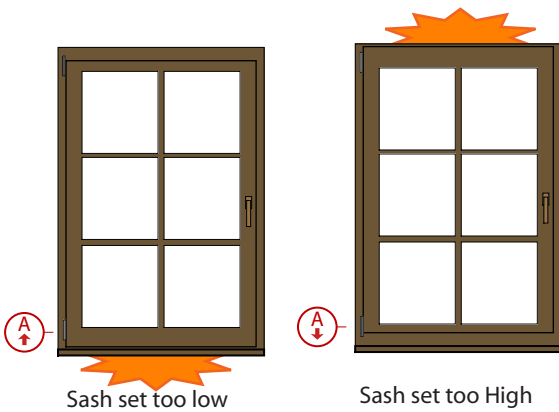

Problem #1

Description: Sash rubs in the upper or lower side.

Cause: Sash is straight, but is set too high or low.

Solution: Adjustment A - move Sash up or down.

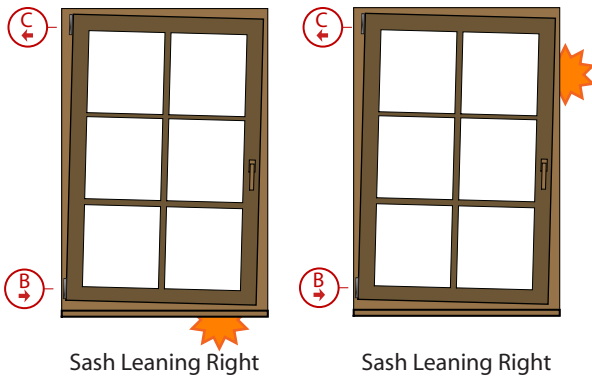

Problem #2

Description: Sash rubs in the lower corner or the upper side.

Cause: Sash is leaning towards the lower hinge.

Solution:

Adjustment C - move Sash away from bottom hinge.

Adjustment A - move Sash down if necessary.

Adjustment B - move Sash towards top hinge.

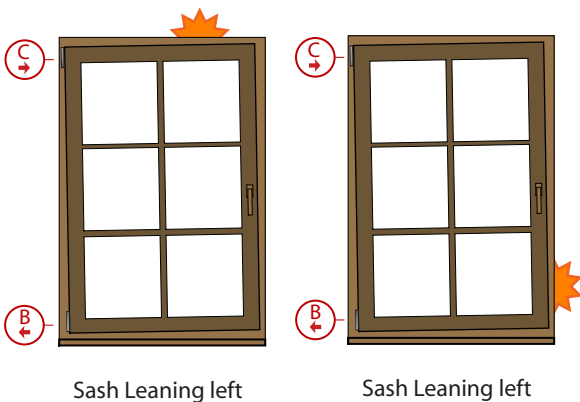

Problem #3

Description: Sash rubs in the upper corner or the lower side.

Cause: Sash is leaning towards the upper hinge.

Solution:

Adjustment C - move Sash towards bottom hinge.

Adjustment A - move Sash down if necessary.

Adjustment B - move Sash away from top hinge.

Adjustment (A) - Sash Height

This adjustment raises or lowers the sash.

1. Open the Window approximately 4"-6"
2. Remove the plastic cover from the lower hinge body
3. Insert the 4 mm Allen key into the top of the bottom hinge
4. Rotate the screw that is inside the Bottom Hinge:
 - To RAISE the sash, rotate the screw in a clockwise direction.
 - To LOWER the sash, rotate the screw in a counter-clockwise direction.
5. Adjust Slowly. With every adjustment, turn the Allen screw 1/4 turn, then operate the window or door to see if you have corrected the problem. Repeat if necessary: turn the screw approximately 1/4 turn each time, until the issue is resolved. When or as you correct the problem with one adjustment, you may cause the sash to bind or hit in another place. This means you may have to make more than one adjustment to correct all of the binding problems.
6. After adjusting, check that the tilt function operates correctly.



Clockwise to Raise the Sash

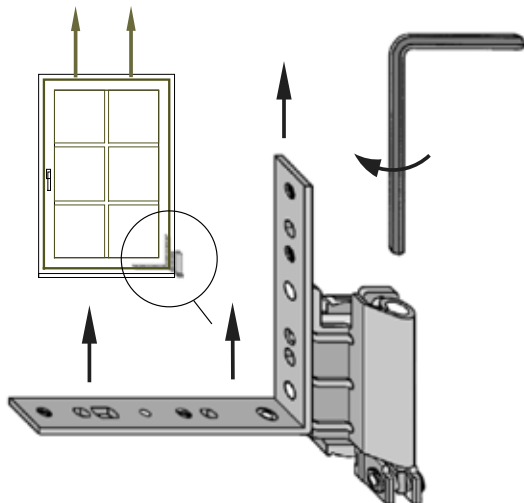

Counter-Clockwise to Lower the Sash

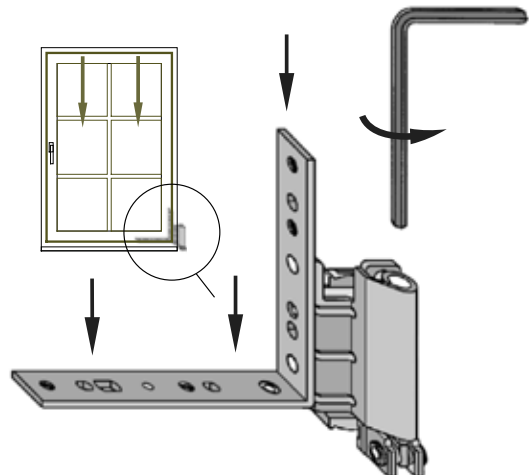

Sash Adjustment (B) -Lower Hinge Offset

This adjustment moves the bottom of the sash towards the upper hinge or away from it. Essentially this adjustment will rock the sash to the left or the right.

1. Open the Window approximately 4"-6".
2. Remove the plastic cover from the lower hinge body .
3. Insert the 4 mm allen key into the top of the bottom hinge.
4. Rotate the nut that is at the bottom of the Hinge:
 - To Pull the Sash closer to the hinge turn the nut to the right.
 - To Push the Sash away from the hinge, turn the nut to the left .
5. Adjust Slowly. With every adjustment, turn the Allen screw 1/4 turn, then operate the window or door to see if you have corrected the problem. Repeat if necessary: turn the screw approximately 1/4 turn each time, until the issue is resolved. When or as you correct the problem with one adjustment, you may cause the sash to bind or hit in another place. This means you may have to make more than one adjustment to correct all of the binding problems.
6. After adjusting, check that the tilt function operates correctly.

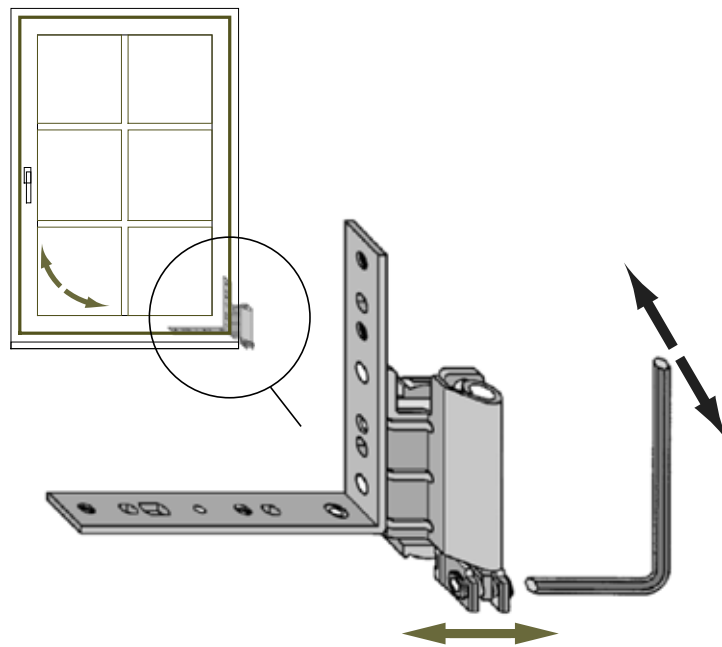

Adjustment (C) -Upper Hinge Offset

This adjustment moves the top of the sash towards the upper hinge or away from it. Essentially this adjustment will rock the sash to the left or to the right.

1. Open the sash as far as it will open.
2. Insert the Allen key into the head of the screw at the end of the shear arm.
3. Turn the Allen screw 1/4 turn in a counter-clockwise or clockwise direction.

Counter-clockwise: To tilt the sash towards the upper hinge, rotate this screw in a counter-clockwise direction. This raises the bottom corner of the sash on the handle side.

Clockwise: To tilt the sash away from the upper hinge, rotate the screw in a clockwise direction. This lowers the bottom corner of the sash on the handle side.

4. Adjust Slowly. With every adjustment, turn the allen screw 1/4 turn, then operate the window or door to see if you have corrected the problem. Repeat if necessary: turn the screw approximately 1/4 turn each time, until the issue is resolved. When or as you correct the problem with one adjustment, you may cause the sash to bind or hit in another place. This means you may have to make more than one adjustment to correct all of the binding problems.
5. After adjusting, check that the tilt function operates correctly.

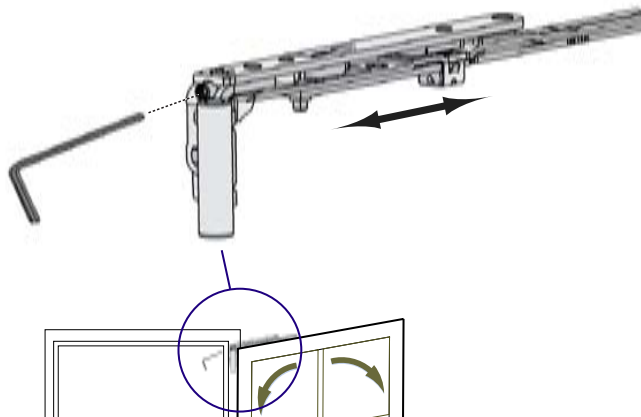

Adjusting an Entry Doors



All adjustments can be made with a 5mm Allen Wrench . You will need to remove the Finish Hinge Caps from all the hinges to access the adjustment point. Each hinge has three adjustment points.



Adjustment A

Clockwise:

Pulls the Door sash closer towards the door frame

Counter-Clockwise:

Pushes the door sash away from the door frame.

Use this adjustment:

When the door slab is hitting or rubbing against the frame or if you have a closing tightness problem.



Adjustment B

Clockwise:

Moves entire door sash up.

Counter-Clockwise:

Moves entire door sash down.

Use this adjustment:

When the door slab is hitting the bottom or top of the frame.



Adjustment C

Clockwise:

Moves sash *towards* the hinge you are adjusting.

Counter-Clockwise:

Moves sash *away from* the hinge you are adjusting.

Use this adjustment when:

When the door slab is hitting or rubbing against the frame. Most often you will use this adjustment in combination with Adjustment B.

Adjustment Tips:

Make small adjustments on all the hinges in unison when necessary. Adjust Slowly. With every adjustment, turn the Allen screw 1/4 turn, then operate the door to see if you have corrected the problem. Repeat if necessary: turn the screw approximately 1/4 turn each time, until the issue is resolved. When or as you correct the problem with one adjustment, you may cause the sash to bind or hit in another place. This means you may have to make more than one adjustment to correct all of the binding problems.

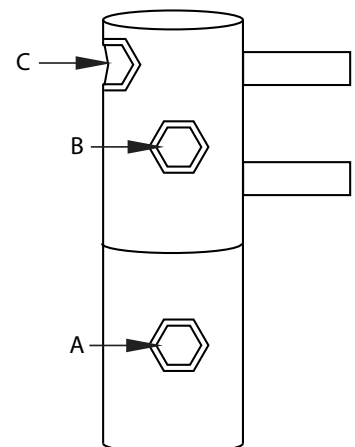

Removal of Window or Patio Door Sash from Frame



figure 1

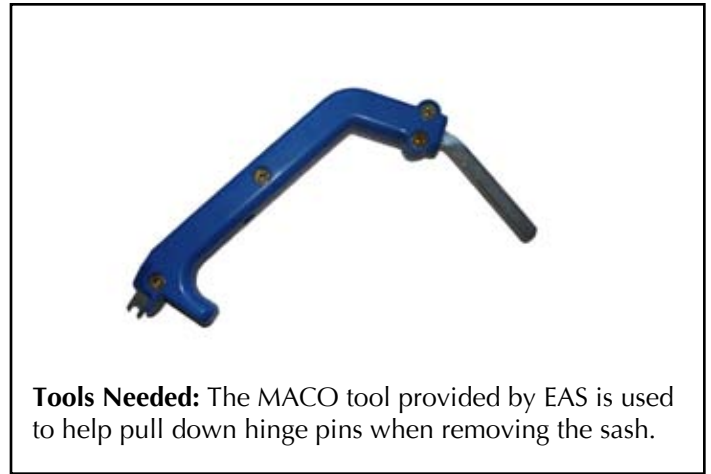

figure 2

- 1. Remove Hinge Covers:** Pull off the hinge covers (*fig. 1*)
- 2. Open the Sash:** Partially open the sash, about 2-3 inches
- 3. Remove Top Hinge Pin:** Have one person support the weight of the sash with two hands. Have the other person pull the hinge pin down. Use the Maco tool (*fig. 2*) to pull the pin down. Pull the hinge pin down until you hear a "Click". The clicking of the hinge pin indicates that the pin is at the lowest point of the hinge. If you pull the hinge pin any further, it will fall out.
- 4. Lift Sash Up-and-Off of Bottom Hinge Pin:** The top of the sash is now free from the frame, only the bottom hinge pin is attached and supporting the sash. To release the sash from the bottom hinge pin, slightly tilt the sash towards you. Next lift the sash up and off of the bottom hinge pin.

Warning!

The sash is heavy.

Two or more people are needed to remove the sash.

Do not try to remove alone.

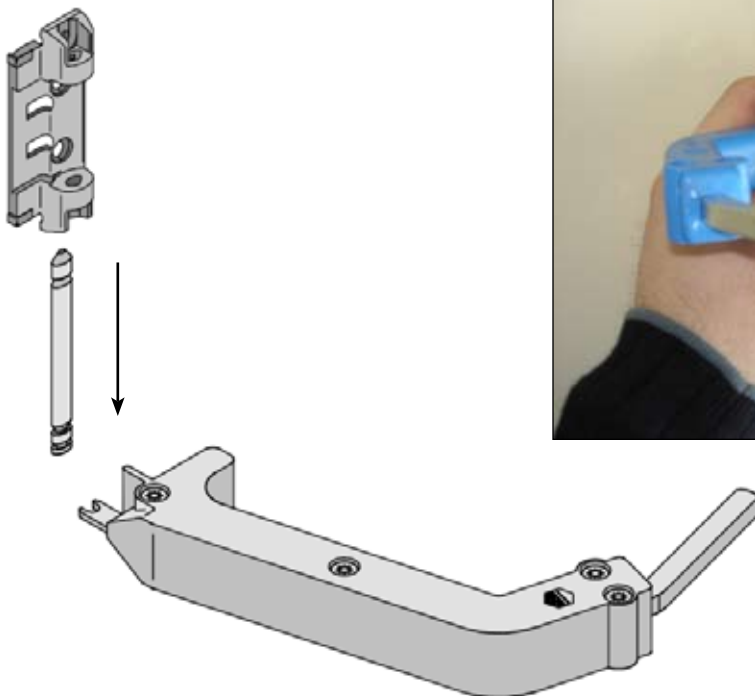

Section 3

Product Care & Maintenance

- **Touch-up Paint & Glazing**
- **Caring for you Windows, Doors and Screens**

Touch-up Glazing and Paint

During construction or throughout the years of being in your home, a window or door might get dented or scratched. For that reason, we provide a complimentary bottle of glazing and/or paint. This is the actual factory finish that was used for the final coat of your windows or doors. Please keep this bottle in a cool dry place and prevent the paint from freezing. Depending on your finish, you might find 1 bottle or 2 bottles.

One Bottle: Touch-up Glazing or Paint:

To Touch-up

- Gently sand the area with 150-220 sand paper .
- Wipe off the sanding dust with a clean dry rag.
- Apply the glazing or paint with a clean soft brush.
- Let the glazing dry for 12-24 hours.
- Once again, gently sand the area with 150-220 sand paper.
- Wipe off the sanding dust with a clean dry rag, then apply the coat
- More than two coats might be needed to achieve a good match to the existing finish.
- Final coat dry time 24 hours.



Two Bottles: Preservative & Glazing:

All of our wood products are finished in three steps. The first step is an impregnation with a wood preservative which acts as a base coat. Then two coats of the finish are sprayed onto the wood.

Not only does this preservative help defend against fungal and insect attacks; it is also used to pigment the wood. Use the preservative when damage is beyond the glazing and into bare wood. You can distinguish the preservative from the glazing, as it is much thinner with the glazing almost being gel-like.

To Touch-up

- If damage is deep into bare wood, first gentle sand, then apply the preservative with a brush.
- Let the preservative dry, about 10-15 minutes
- Next apply the glazing with a brush. The glazing is relatively thick and unlike most paints, you may apply it in thick coat.
- Let the glazing dry for 12-24 hours.
- Gently sand the area with 150-220 sand paper.
- Wipe off the sanding dust with a clean dry rag, then apply another coat
- More than two coats might be needed to achieve a good match to the existing finish.
- Final coat dry time 24 hours.



Clean-up:

All of our preservatives, glazings and paints are water based. To clean-up use warm soapy water.

Caring for your Wood Windows and Doors

Wood products can last centuries if they are maintained properly. Windows and doors need periodic care in order to ensure a long durability and proper function. Naturally your windows and doors are subject to mixture of weather conditions and because of the various types of architectural and installation solutions, there is no rule which specifies how often these maintenance activities should be made. We can only say that wood windows and doors exposed to the South need a particular attention because sun is the worst enemy of the wood. A good habit would be to inspect, clean and adjust as necessary every six months. It is very important to understand that preventive treatments are essential to avoid severe damage in the future.

Cleaning:

The buildup of dirt and soot and other harmful contaminants on the exterior of any window or door is very common and extremely damaging if not cleaned periodically. This dirt and soot is typically acidic and will deteriorate any finish overtime. You'll find that dirt and soot usually builds up on surfaces that are not flat (muntins, panels, trim pieces, carvings)

Cleaning the Wood

To preserve a healthy finish, periodically wipe down the exterior of your window or door with a damp dust free soft cloth. If you find that the soot and dirt buildup is excessive, use a very-light-soapy warm water solution with a dust free soft cloth. Repeat process with a clean damp cloth (just water solution) if any surface soapy residue remains. Once the wood is dry and free of heavy dust and soot -Formby's® Almond Lustre® can also be used to clean and protect the wood finish (Do not use any cleaning products that contain petroleum, waxes or vegetable oil soaps. The best cleaners have a neutral pH and have no wax build-up. Always read the Manufactures product label before use)

Cleaning the Glass

You can usually remove dust, dirt, smoke, film, soot and salt spray by using a mild detergent and water solution and a soft cloth. To remove heavy dirt or grime from glass, first wipe loose debris from the glass surface with a soft, dry cloth. Then apply a cleaning solution, such as mild soapy water, vinegar or a window cleaner.. Remove cleaning solution with a squeegee or a clean, lint-free cloth. Never clean glass in direct sunlight. To avoid damage to the glass, never use razor blades or anything abrasive on glass surface.

Cleaning Insect Screens

You can usually remove dust, dirt, smoke, film, soot and salt spray from grilles using a mild detergent and water solution and a soft cloth or brush. To remove grease, oil or industrial solids, you may need to use stronger solutions cleaning solutions or rubbing alcohol. Insect screens are best cleaned with a garden hose and soapy water. If they have been neglected, wash them with a detergent and water, using a soft-fiber brush.